



DSH 86系列

DSH 86 SERIES

規格表

6 線式規格表

1 gf-cm=0.001 kgf-cm 1 gf-cm=0.000098 N-m

馬達編號	步進角 (度)	額定電壓 (VDC)	額定電流 (A/相)	握持扭矩 (gf-cm)	線圈阻抗 ($\Omega \pm 10\%$ /相)	線圈感抗 (mH $\pm 20\%$ /相)	轉子慣量 (g-cm ²)	重量 (gw)
DSH86DS6TA	0.9	3.2	2.85	13000	1.1	3.7	560	1400
DSH86DM61A	0.9	3.0	4.0	26000	0.75	4.0	1100	2650
DSH86DL61A	0.9	12	1.8	40000	6.5	43	1800	3600
DSH86ES61A	1.8	1.8	4.5	13000	0.4	1.5	560	1400
DSH86ES62A	1.8	5.5	1.25	14000	4.4	16	560	1400
DSH86EM61A	1.8	3.0	4.0	26000	0.75	4.2	1100	2650
DSH86EM62A	1.8	6.0	2.0	28000	3.0	16	1100	2650
DSH86EM63A	1.8	12	1.0	28000	12	72	1100	2650
DSH86EL61A	1.8	12	1.8	35000	6.6	40	1800	3700
DSH86EL62A	1.8	5.0	4.0	40000	1.25	7.0	1800	3700

8 線式規格表

1 gf-cm=0.001 kgf-cm 1 gf-cm=0.000098 N-m

馬達編號	步進角 (度)	額定電壓 (VDC)	額定電流 (A/相)	握持扭矩 (gf-cm)	線圈阻抗 ($\Omega \pm 10\%$ /相)	線圈感抗 (mH $\pm 20\%$ /相)	轉子慣量 (g-cm ²)	重量 (gw)
DSH86DX81A	0.9	3.3	2.0	9500	1.65	2.1	560	1400
DSH86EX82A	1.8	2.3	3.0	8500	0.75	1.1	560	1400
DSH86ES84A	1.8	1.9	4.2	13000	0.45	1.1	560	1400

● 其他特殊規格請與東元精電或經銷商洽詢

尺寸圖

DIMENSION (UNIT :mm)

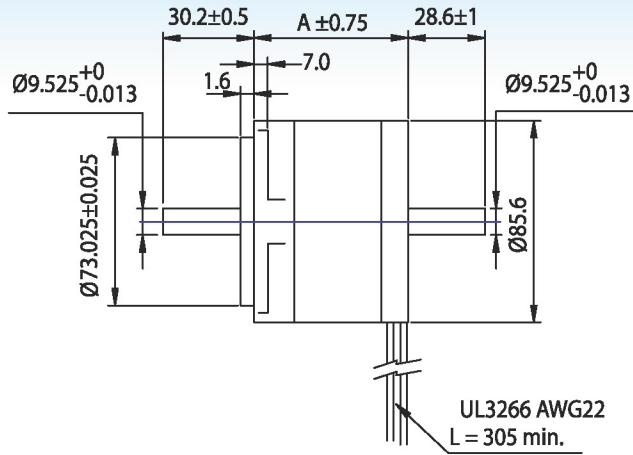
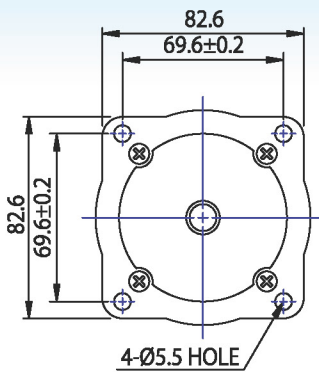

DIM.	A
S	62
M	94
L	128

扭力曲線表

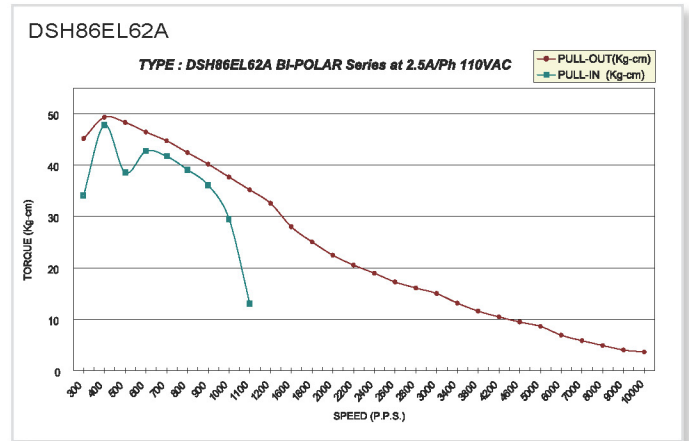
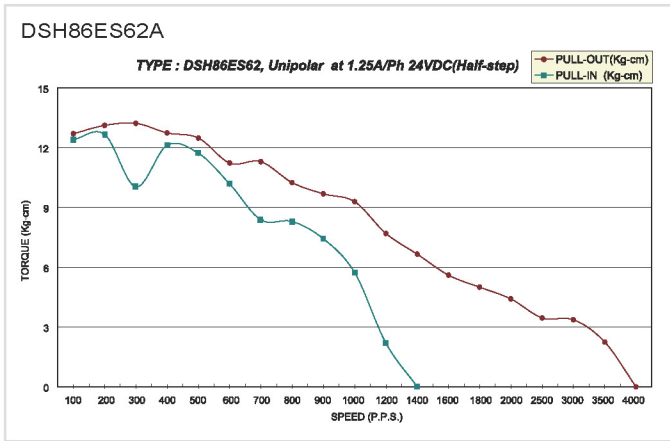

出線線色 · 接線 · 驅動方式

● 6線式馬達

WIRING DIAGRAM

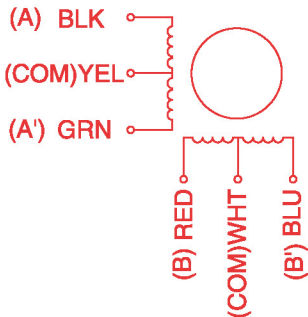

● 8線式馬達

WIRING DIAGRAM

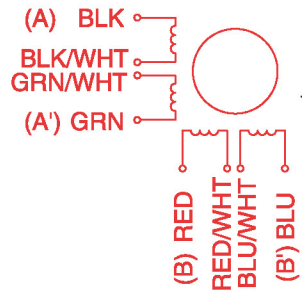

Unipolar ;
兩相激磁

STEP	黑 Black A	紅 RED B	綠 Green A	藍 Blue B	COM	CCW ↑
1	ON	ON			+DCV	↓ CW
2		ON	ON			
3			ON	ON		
4	ON			ON		